

**TB 11-5840-384-20**

---

**TECHNICAL BULLETIN**

**DESERT OPERATIONS  
CLEANING REQUIREMENTS:**

**RADAR SET  
AN/TPN-18A  
NSN 5840-01-070-9415**

**LANDING CONTROL CENTRAL  
AN/TSQ-71/B  
NSN 5895-01-092-8074**

**AIR TRAFFIC CONTROL CENTRAL  
AN/TSW-7A  
NSN 5895-01-018-1246**

**COMMAND SYSTEM,  
TACTICAL AIRSPACE INTEGRATION SYSTEM (TAIS)  
AN/TSQ-221  
NSN 5895-01-476-4132**

**TACTICAL TERMINAL CONTROL SYSTEM  
AN/TSQ-198  
NSN 5840-01-388-1454**

**RADIO BEACON SETS,  
AN/TRN-30(V)  
NSN 5825-00-423-1654**

**AIR TRAFFIC NAVIGATION, INTEGRATION & COORDINATION SYSTEM,  
AN/TPN-31  
NSN 5840-01-450-8126**

This Technical Bulletin supersedes TB 11-5840-384-20 dated 1 May 2004

DISTRIBUTION STATEMENT A - Approved for public release; distribution is unlimited

---

**Headquarters, Department of the Army**

**15 June 2006**



# TB 11-5840-384-20

INSERT LATEST CHANGED PAGES. DESTROY SUPERSEDED DATA.

## LIST OF EFFECTIVE PAGES

NOTE: The portion of text affected by the changes is indicated by a vertical line in the outer margins of the page. Changes to illustrations are indicated by miniature pointing hands. Changes to wiring diagrams are indicated by shaded areas.

Dates of issue for original and changed pages / work packages are:

Original 15 June 2006

<u>Page No.</u>	<u>Change</u>	<u>No</u>
A/(B blank)		0
i thru ii		0
1-1 thru 1-30		0



# TB 11-5840-384-20

---

HEADQUARTERS  
DEPARTMENT OF THE ARMY  
WASHINGTON, D.C., 15 JUNE 2006

**TECHNICAL BULLETIN  
DESERT OPERATIONS  
CLEANING REQUIREMENTS:**

**RADAR SET  
AN/TPN-18A  
NSN 5840-01-070-9415**

**LANDING CONTROL CENTRAL  
AN/TSQ-71/B  
NSN 5895-01-092-8074**

**AIR TRAFFIC CONTROL CENTRAL  
AN/TSW-7A  
NSN 5895-01-018-1246**

**COMMAND SYSTEM,  
TACTICAL AIRSPACE INTEGRATION SYSTEM (TAIS)  
AN/TSQ-221  
NSN 5895-01-476-4132**

**TACTICAL TERMINAL CONTROL SYSTEM  
AN/TSQ-198  
NSN 5840-01-388-1454**

**RADIO BEACON SETS,  
AN/TRN-30(V)  
NSN 5825-00-423-1654**

**AIR TRAFFIC NAVIGATION, INTEGRATION & COORDINATION SYSTEM,  
AN/TPN-31  
NSN 5840-01-450-8126**

**REPORTING ERRORS AND RECOMMENDING IMPROVEMENTS**

You can help improve this manual. If you find any mistakes, or if you know of a way to improve the procedures, please let us know. We d prefer that you submit your recommended changes electronically, either by e-mail ([AMSEL-LC-LEO-PUBS-CHG@mail1.monmouth.army.mil](mailto:AMSEL-LC-LEO-PUBS-CHG@mail1.monmouth.army.mil)) or online (<http://edm.monmouth.army.mil/pubs/2028.html>). Alternatively, you may mail or fax your letter, DA Form 2028 (Recommended Changes to Publications and Blank Forms) or DA Form 2028-2 located in back of this manual to: Commander, US Army Communications-Electronics Life Cycle Management Command (CE-LCMC), Fort Monmouth, ATTN: AMSEL-LC-LEO-E-ED, Fort Monmouth, NJ 07703-5006. The fax number is 732-532-3421, DSN 992-3421.  
In any case, we will send you a reply.

This Technical Bulletin supersedes TB 11-5840-384-20 dated 1 May 2004

DISTRIBUTION STATEMENT A - Approved for public release; distribution is unlimited

**Table of Contents**

1.	AN/TPN-18A.....	1-1
2.	Landing Control Central, AN/TSQ-71/B and AN/TSQ-71/B (Modified) .....	1-6
3.	Air Traffic Control Central, AN/TSW-7A.....	1-15
4.	Command System, Tactical Airspace Integration System (TAIS) AN/TSQ-221 .....	1-19
5.	Tactical Terminal Control System (TTCS), AN/TSQ-198.....	1-21
6.	Beacon Sets, Radio AN/TRN-30(V) .....	1-24
7.	Air Traffic Navigation, Integration & Coordination System, AN/TPN-31 .....	1-28
8.	Authorization and DA Form 2028 Reports .....	1-30

**CHAPTER 1.**

1. Purpose. Provide a cleaning requirement to remove salt / salt laden sand and other corrosive contaminants from radar set AN/TPN-18A returning from OCONUS Desert Operations.

Environmental conditions within the Southwest Asia (SWA) theater of operations were conducive to the introduction of salt laden sand and other corrosive substances into the interior surfaces of the radar. These substances, if allowed to remain will accelerate the corrosion process and lead to premature corrosion damage. Immediate removal of these substances is imperative in order to minimize future corrosion damage. This Technical Bulletin (TB) is issued to provide special inspection and cleaning procedures for all deployed/redeployed radar sets.

2. Priority Classification. NORMAL.

a. **Equipment In Use.** No later than 30 days after redeployment from Desert operations. Deployed radar sets will complete cleaning procedures as necessary but as a minimum at next preventative maintenance checks and services (PMCS).

b. **Equipment in Storage.** No later than 30 days after redeployment from Desert operations. Equipment deployed will complete cleaning procedures as necessary but as a minimum quarterly.

3. End Items to be inspected. All radar sets after redeployment from Desert operations. Deployed radar sets will complete requirements as necessary but at a minimum at next phase.

4. Assembly Components to be Inspected. Not applicable

5. Parts to be Inspected. Receiver/Transmitter Group.

6. Application.

a. Category of Maintenance organizational/Direct Support (UNIT Level).

b. Time Required. As required to comply with this TB.

c. Estimated Cost Impact of Stock Fund Items to the Field. Not applicable.

d. TB / MWOs applied prior to or concurrently with this inspection. Not applicable.

e. Publications which require change as a result of this inspection. Not applicable.

7. Supply / Parts and Disposition.

a. Parts Required. Not applicable.

b. Requisitioning Instructions. Requisition materials through normal supply channels using normal supply procedures. Requests should be the highest priority authorized by Force Activity Designator (FAD). If the delivery is forecasted to be in excess of 21 days; or if materials are not received within 21 days of ordering contact your local GSA Customer Service Center DSN 695-4865 as appropriate to specific item of concern. If unable to requisition items within the allotted time frame contact one of the POCs listed in this TB.

# TB 11-5840-384-20

c. Bulk and Consumable Materials.

NOMENCLATURE	PART NO/NSN	U/I	QUANTITY REQ
Cloth, cheesecloth, lint-free	8305-00-267-3015	YD	
Crocus Cloth	5350-00-221-0872	50 sh	

8. Special Tools, Jigs and Fixtures Required. Not applicable.

9. Inspection Procedures. Only applicable to radar sets redeploying.

10. Cleaning Procedures.

- a. Using a lint-free cloth, clean exterior surfaces of equipment and mechanical assemblies. Dampen cloth (not wet) with warm sudsy water to remove ground-in dirt, grease, and fungus.
- b. With a clean lint-free cloth and soft-bristled brush, clean plugs, jacks, and front panel controls and indicators. Meter faces and front panels may be cleaned using a weak solution of water and mild soap. Avoid excessive amount of solution on cloth and do not let solution enter behind controls or panel mounting hardware of controls and indicators.
- c. Clean exterior and pins of connectors of interconnecting cables with a brush. Cleaning compound may be used with brush and cloth to remove grease, fungus, and light tarnish.
- d. There are four air filters: one in bottom of receiver-transmitter, one in receiver side door of receiver-transmitter, and one in bottom front of each pulse generator drawer. Tap edges of air filters to remove as much dirt as possible. Wash air filters in warm sudsy water, using brush to remove dirt from wire mesh. Allow filters to drain by supporting on suitable surface with airflow arrows on sides of filters pointing upward.
- e. **Inspect/clean:**
  - Receiver-Transmitter air-vent cover.
  - Radar Set Group - Air filters in bottom of receiver-transmitter and in receiver door
  - Control-Indicator Group - Air filters in bottom left front of both pulse generators (master and slave).
  - Receiver-Transmitter Internal Components - Open receiver and transmitter doors and clean.
  - Control-Indicator - Remove indicator access cover on side of shelter to expose control indicator and clean.
- f. Clean reflective surfaces on antennas and covers on feedhorn and polarizer assemblies with soft, lint-free cloth. Cloth may be used with weak solution of water and mild soap. Ground-in dirt, if necessary, can be removed with a cloth dampened (not wet) with cleaning compound and used sparingly.



## Transmitter Control Unit (TCU)

1. Loosen 7 externally retained thumbscrews and remove outside protective panel.
2. Loosen 8 captive screws and open door.

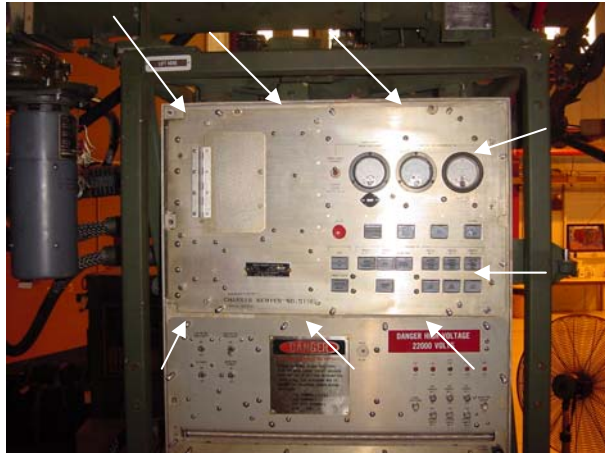

3. Remove cover from inside unit by loosening 12 captive screws, and swing unit outward. Brush everything lightly and blow dirt, dust and sand out.
4. Reinstall cover panel.

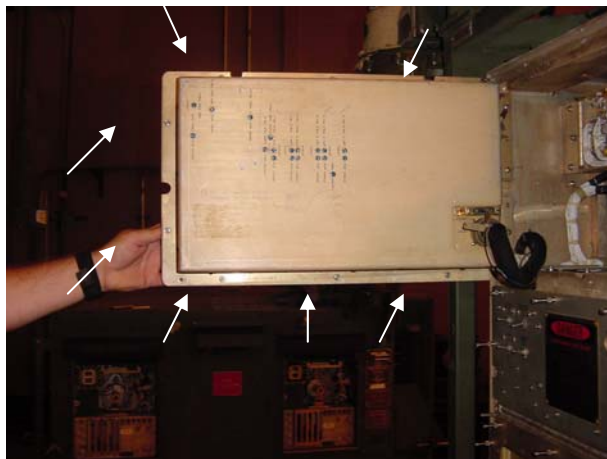

5. Behind TCU, remove cover on remote switch deck by removing 6 screws.
6. Brush everything lightly and blow dirt, dust and sand out.

## TB 11-5840-384-20

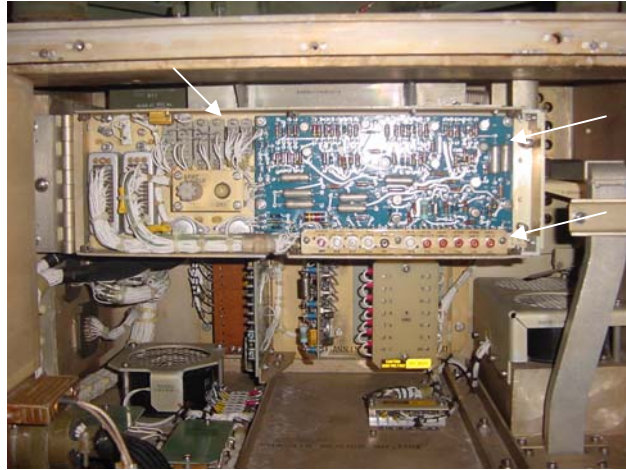

7. On front door open card cage door by loosening 2 captive screws.

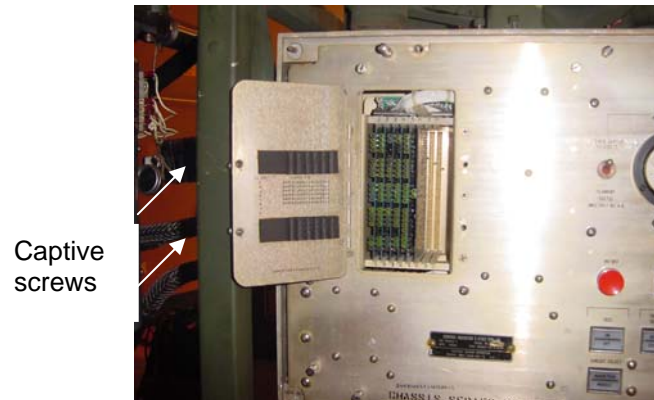

8. Remove cards and sweep out cage and wipe down cards
9. Reinstall cards.

### Power Control Panel

1. Loosen 6 captive screws and drop panel down.
2. Brush and blow out compartment, being careful of all wires and connectors.



## Transmitter Assembly

1. Loosen 6 captive screws and drop panel down.
2. Remove 4 boards a carefully disconnect wire leads.
3. Brush and blow out compartment, and boards.
4. Remove filter on bottom wash, let dry and reinstall.
5. Reinstall boards and close unit

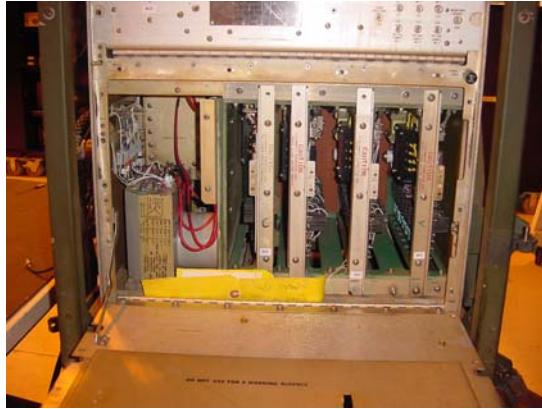

### 13. Points of Contact.

- a. Point of contact for this action is ATSCOM, ATTN:AFATS-S4-MR DSN 558-3494 or Commercial 334-255-3494
- b. Technical point of contact is ATSCOM, ATTN:AFATS-S4-MR DSN 558-3494 or Commerical 334-255-3494

### 15. Reporting of Errors and Recommending Improvements.

You can help improve this publication. If you find any mistakes or if you know of a way to improve the procedures, please let us know. Mail your letter or DA Form 2028 (Recommended Changes to Publications and Blank Forms) directly to : Commander, U.S. Army Aviation Systems Command, ATTN: A reply will be furnished to you.

# TB 11-5840-384-20

## CHAPTER 2.

1. Purpose. Provide a cleaning requirement to remove salt / salt laden sand and other corrosive contaminants from Landing Control Central AN/TSQ-71B and AN/TSQ-71B (modified) returning from OCONUS Desert Operations. Environmental conditions within the Southwest Asia (SWA) theater of operations were conducive to the introduction of salt laden sand and other corrosive substances into the interior surfaces of the Landing Control Central. These substances, if allowed to remain will accelerate the corrosion process and lead to premature corrosion damage. Immediate removal of these Substances is imperative in order to minimize future corrosion damage. This Technical Bulletin (TB) is issued to provide special inspection and cleaning procedures for all deployed/redeployed Landing Control Central facilities.
2. Priority Classification. NORMAL.
  - a. Equipment in Use. No later than 30 days after redeployment from Desert operations. Deployed Landing Control Central facilities will complete cleaning procedures as necessary but as a minimum at next PMCS.
  - b. Equipment in Storage. No later than 30 days after redeployment from Desert Operations. Equipment deployed will complete cleaning procedures as necessary but as a minimum quarterly.
3. End Items to be Inspected. All Landing Control Central facilities after redeployment from Desert operations. Deployed Landing Control Central facility will complete requirements as necessary but at a minimum at PMCS.
4. Assembly Components to be Inspected. Not applicable
5. Parts to be Inspected. Not applicable.
6. Application.
  - a. Category of Maintenance - Organizational/Direct Support (UNIT Level).
  - b. Time Required. As required to comply with this TB.
  - c. Estimated Cost Impact of Stock Fund Items to the Field. Not applicable.
  - d. TB/MWOs applied prior to or concurrently with this inspection. Not applicable.
  - e. Publications which require change as a result of this inspection. Not applicable.
7. Supply / Parts and Disposition.
  - a. Parts Required. Not applicable.
  - b. Requisitioning Instructions. Requisition materials through normal supply channels using normal supply procedures. Requests should be the highest priority authorized by Force Activity Designator (FAD). If the delivery is forecasted to be in excess of 21 days; or if materials are not received within 21 days of ordering contact your local GSA Customer Service Center DSN 695-4865 as appropriate to specific item of concern. If unable to requisition items within the allotted time frame contact one of the POCs listed in this TB.

c. Bulk and Consumable Materials.

NOMENCLATURE	PART NO/NSN	U/I	QUANTITY REQ
FREON PCA, Type T	6850-00-105-3084	pt	
Sandpaper, Fine, (P-P-105)	5350-00-264-3485	pgk	

- 8. Special Tools, Jigs and Fixtures Required. Not applicable.
- 9. Inspection Procedures. Only applicable to Ground Controlled Approach facility redeploying.
- 10. Cleaning Procedures.

**NOTE**

Keep in mind all warnings and cautions when performing any routine cleaning

- a. Using a lint-free cloth, clean exterior surfaces of equipment and mechanical assemblies.
- b. With a clean lint-free cloth and soft-bristled brush, clean plugs, jacks, and front panel controls and indicators.
- c. Clean exterior and pins of connectors of interconnecting cables with a brush.
- d. Inspect/clean:

**WARNING**

All Procedures done with power removed from shelter.

**Power Distribution Panel:**

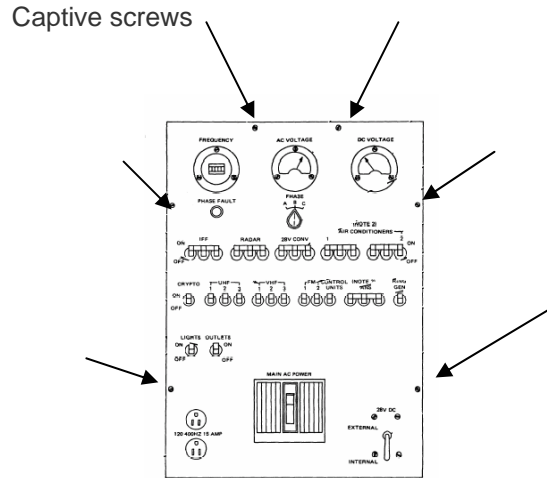

1. Remove protective guard if on the front if installed.
2. Loosen (6) captive screws and drop face plate down carefully
3. Carefully brush down insides with wish brush or blow out with compressed air if available removing all dirt, sand and dust form interior.
4. Close panel and tighten thumbscrews.
5. Wipe down with damp cloth front panel.
6. Replace protective guard.



**Pulse Generator Drawer**

1. Pull drawer out completely, tag and disconnect cables from the rear and remove entire drawer from slides on the rack.

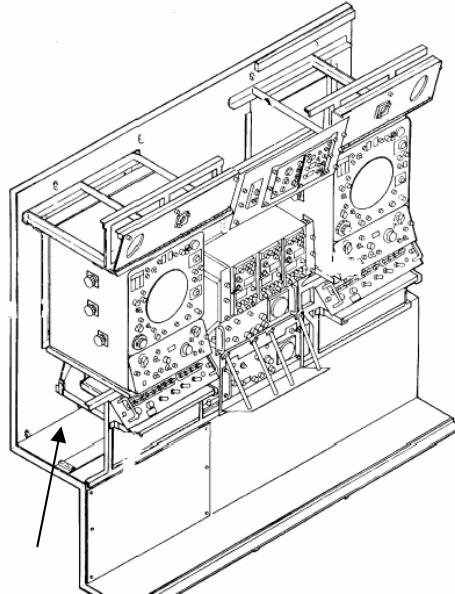

2. Carefully brush down inside compartment with wisk brush or blow out with compressed air if available removing all dirt, sand and dust form interior.
3. Remove drawer from shelter and carefully clean components with brush or compressed air until all dirt, dust and sand are removed.
4. Reinstall drawer to slides and connect cables, close drawer.

# TB 11-5840-384-20

## Radio and Telephone Control Panels

1. Open front panel doors by loosening (2) captive crews located at the top corners of panel, drop face plate down carefully
2. Carefully brush down inside compartment with wish brush and blow out with compressed air removing all dirt, sand and dust from interior and components.
3. Close panel and tighten captive screws.
4. With damp cloth wipe down front panel.

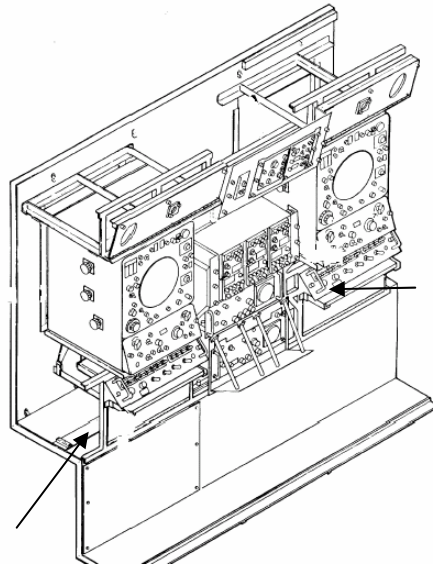

Captive screw



**Radio Telephone, Control Panel**

1. Pull drawer out completely, tag and disconnect cables from the rear and remove entire drawer from slides on the rack.

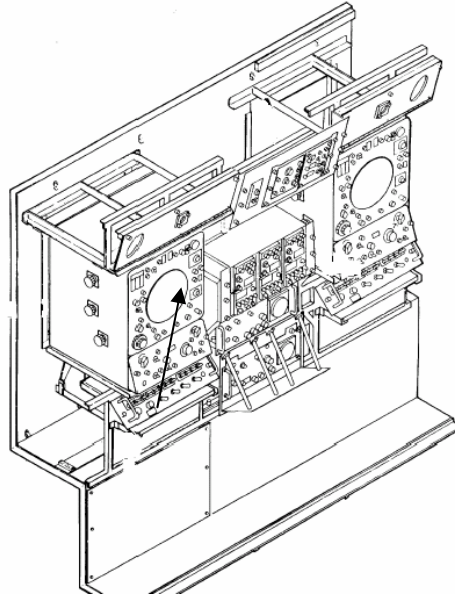

2. Carefully brush down inside compartment with wisk brush or blow out with compressed air if available removing all dirt, sand and dust form interior.
3. Remove drawer from shelter and carefully clean components with brush or compressed air until all dirt, dust and sand are removed.
4. Reinstall drawer to slides and connect cables, close drawer.

# TB 11-5840-384-20

## Indicator Access Cover

1. Remove 16 thumb screws around the outside panel, and remove panel.
2. Remove 2 screws and plug on the back of CRT.
3. Remove Mixer Amplifier circuit board and

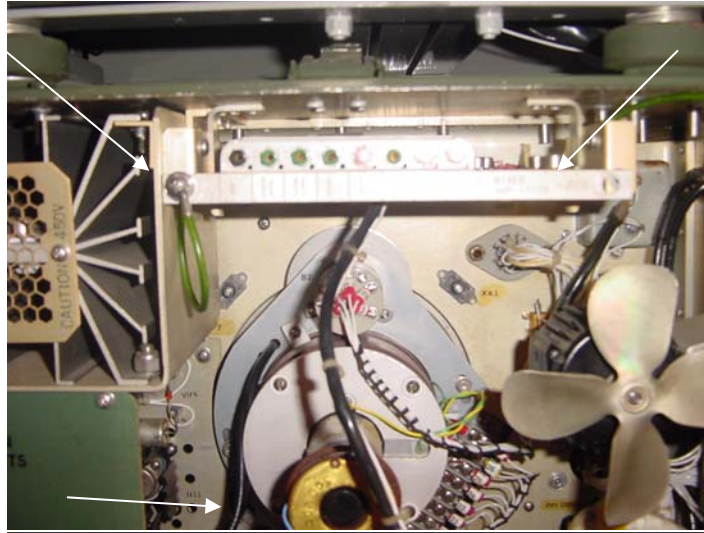

4. Clean tube socket for CRT.
5. Remove 5 screws on Power supply and slide out and set aside.
6. Remove 4 screws that hold card cage and pull out.
7. Remove cards and blow and brush clean card cage and boards with brush and compressed air.

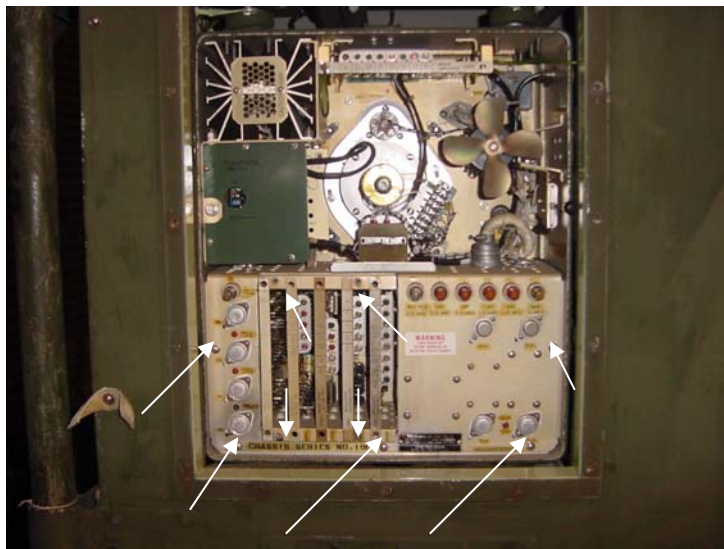

8. Brush and blow out compartment with brush and compressed air.
9. Reinstall all components in reverse order and reinstall cover panel.

**Video Decoder and IFF Receiver Transmitter**

1. Loosen 4 captive screws from front of drawer

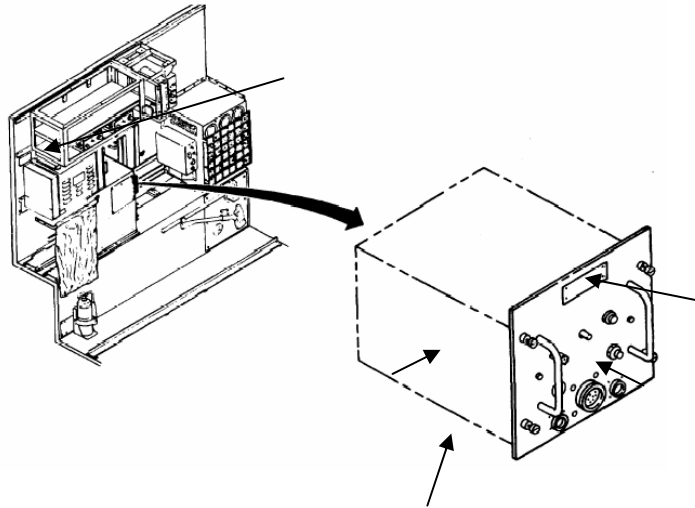

2. Pull out far enough to tag and remove cables in rear.
3. Remove chassis and set aside.
4. Clean out chassis housing with brush and compressed air.
5. Reinstall cables and secure chassis.

# TB 11-5840-384-20

## External Vents

1. Brush all external vents with brush and remove all dirt dust and sand from outside grills, located on 3 sides of shelter.

## Door Vents

1. On inside door remove 4 screws and grill from door panel.
2. Remove and wash filter in warm sudsy water. Let Dry and reinstall filter.



Shelter - Check entrance panel dust covers and/or receptacle covers on all unused cable receptacles.

Air Conditioners - Check for dirty filter. Agitate filters in water with mild detergent or soap. Rinse and shake dry.

Radar Set AN/TPN-18A - refer to TB 11-5840-281-20, Chapter 1

- a. Point of contact for this action is ATSCOM, ATTN:AFATS-S4-MR DSN 558-3494 or Commercial 334-255-3494
- b. Technical point of contact is ATSCOM, ATTN:AFATS-S4-MR DSN 558-3494 or Commercial 334-255-3494

**CHAPTER 3.**

1. Purpose. Provide a cleaning requirement to remove salt / salt laden sand and other corrosive contaminants from Air Traffic Control Central AN/TSW-7A returning from OCONUS Desert Operations.

Environmental conditions within the Southwest Asia (SWA) theater of operations were conducive to the introduction of salt laden sand and other corrosive substances into the interior surfaces of the Air Traffic Control Central facility. These substances, if allowed to remain will accelerate the corrosion process and lead to premature corrosion damage. Immediate removal of these Substances is imperative in order to minimize future corrosion damage. This Technical Bulletin (TB) is issued to provide special inspection and cleaning procedures for all deployed/redeployed Air Traffic Control Central facilities.

2. Priority Classification. NORMAL.

- a. Equipment In Use. No later than 30 days after redeployment from Desert operations. Deployed Air Traffic Control Central facility will complete cleaning procedures as necessary but as a minimum at next PMCS.
- b. Equipment in Storage. No later than 30 days after redeployment from Desert Operations. Equipment deployed will complete cleaning procedures as necessary but as a minimum quarterly.

3. End Items to be Inspected. All Air Traffic Control Central facilities after redeployment from Desert operations. Deployed Air Traffic Control Central facility will complete requirements as necessary but at a minimum at next PMCS.

4. Assembly Components to be Inspected. Not applicable

5. Parts to be Inspected. Not applicable.

6. Application.

- a. Category of Maintenance - Organizational/Direct Support (UNIT Level).
- b. Time Required. As required to comply with this TB.
- c. Estimated Cost Impact of Stock Fund Items to the Field. Not applicable.
- d. TB/MWOs applied prior to or concurrently with this inspection. Not applicable.
- e. Publications which require change as a result of this inspection. Not applicable.

7. Supply / Parts and Disposition.

- a. Parts Required. Not applicable.
- b. Requisitioning Instructions. Requisition materials through normal supply channels using normal supply procedures. Requests should be the highest priority authorized by Force Activity Designator (FAD). If the delivery is forecasted to be in excess of 21 days; or if materials are not received within 21 days of ordering contact your local GSA Customer Service Center DSN 695-4865 as appropriate to specific item of concern. If unable to requisition items within the allotted time frame contact one of the POCs listed in this TB.

# TB 11-5840-384-20

c. Bulk and Consumable Materials.

NOMENCLATURE	PART NO/NSN	U/I	QUANTITY REQ

- 8. Special Tools, Jigs and Fixtures Required. Not applicable.
- 9. Inspection Procedures. Only applicable to Air Traffic Control Central facility redeploying.
- 10. Cleaning Procedures.

## NOTE

Keep in mind all warnings and cautions when performing any routine cleaning

## WARNING

Compressed air shall not be used for cleaning purposes except where reduced to less than 29 pounds per square inch (psi) and then only with effective chip guarding and personnel protective equipment. Compressed air is dangerous and can cause serious bodily harm if protective means or methods are not observed to prevent chip or particle (of whatever size) from being blown into the eyes or unbroken skin of the operator or other personnel.

- a. Exterior Shelter and Equipment Cleaning.
  - 1. Sweep all large particles of dirt and waste from the roof, walls, stairway, and platform.
  - 2. Remove dirt accumulation from the roof, walls, protective screens, stairway, and platform.
  - 3. Remove all oil and grease accumulations from the shelter exterior and equipment with warm sudsy water and a clean cloth.
  - 4. Use glass cleaner, clean cloths and a squeegee to clean all external glass surfaces. Polish the glass after cleaning with a dry, clean cloth.



b. Interior Shelter Cleaning.

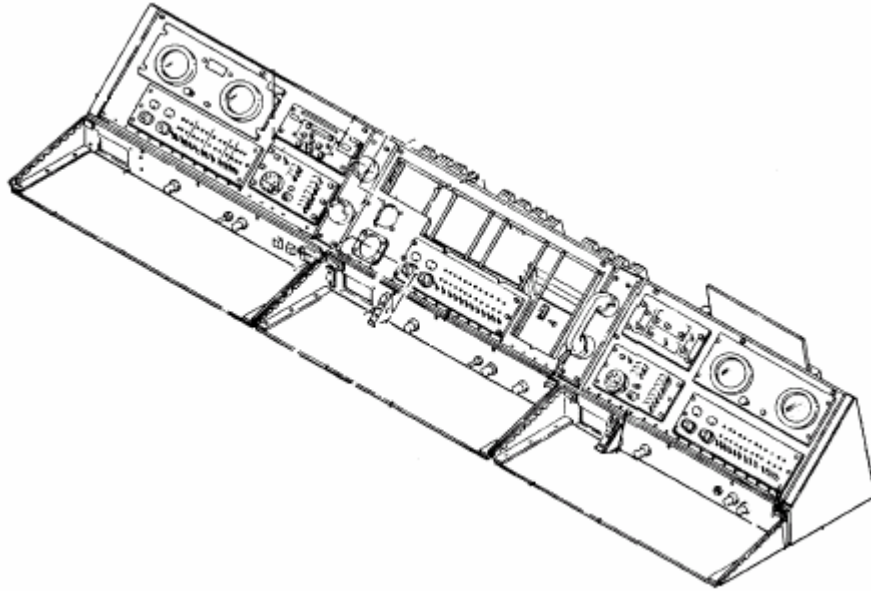

1. Sweep up all large particles of dirt and waste material on the floor. Use a stiff brush to remove hardened accumulations of dirt or mud.
2. Vacuum the floor walking area and beneath the-control console to remove fine dirt particles and dust.
3. Damp mop the floor walking area.
4. Use glass cleaner and clean cloths to clean all interior glass surfaces. Use clean dry cloths to polish the glass after cleaning.
5. Using a clean cloth and solvent, remove all oil and grease accumulations from walls, floor, and electronic equipment.
6. Wipe panels, knobs, dials, switches, and lights with a dry cloth. Use a damp cloth to remove stubborn stains.

## TB 11-5840-384-20

- c. Dust Filter Cleaning Instructions.
  - 1. Tap the filter to remove loose dirt.
  - 2. Flush with water and detergent to loosen the trapped dirt within the filter.
  - 3. Rinse by flushing the water in the opposite direction to airflow direction indicated by green arrow.
  - 4. Tap to remove excess water; allow filter to dry, and replace.



- d. Power Generating Equipment: Storage Battery, Battery Charging Circuit, Environmental Control Units - Inspect and clean.

11. Weight and Balance. Not applicable.

12. Recording and Reporting Requirements. Not applicable.

13. Points of Contact.

- a. Point of contact for this action is ATSCOM, ATTN:AFATS-S4-MR DSN 558-3494 or Commercial 334-255-3494
- b. Technical point of contact is ATSCOM, ATTN:AFATS-S4-MR DSN 558-3494 or Commercial 334-255-3494



**CHAPTER 4.**

1. Purpose. Provide a cleaning requirement to remove salt / salt laden sand and other corrosive contaminants from TAIS returning from OCONUS Desert Operations. Environmental conditions within the Southwest Asia (SWA) theater of operations were conducive to the introduction of salt laden sand and other corrosive substances into the interior surfaces of the TAIS. These substances, if allowed to remain will accelerate the corrosion process and lead to premature corrosion damage. Immediate removal of these Substances is imperative in order to minimize future corrosion damage. This Technical Bulletin (TB) is issued to provide special inspection and cleaning procedures for all deployed/redeployed TAIS.
2. Priority Classification. NORMAL.
  - a. Equipment In Use. No later than 30 days after redeployment from Desert operations. Deployed TAIS will complete cleaning procedures as necessary but as a minimum at next PMCS.
  - b. Equipment in Storage. No later than 30 clays after redeployment from Desert Operations. Equipment deployed will complete cleaning procedures as necessary but as a minimum quarterly.
3. End Items to be Inspected. All TAIS after redeployment from Desert operations. Deployed TAIS will complete requirements as necessary but at a minimum at next PMCS.
4. Assembly Components to be Inspected. Not applicable
5. Parts to be inspected. Not applicable.
6. Application.
  - a. Category of Maintenance - Organizational/Direct Support (UNIT Level).
  - b. Time Required. As required to comply with this TB.
  - c. Estimated Cost Impact of Stock Fund Items to the Field. Not applicable.
  - d. TB / MWOs applied prior to or concurrently with this inspection. Not applicable.
  - e. Publications which require change as a result of this inspection. Not applicable.
7. Supply / Parts and Disposition.
  - a. Parts Required. Not applicable.
  - b. Requisitioning Instructions. Requisition materials through normal supply channels using normal supply procedures. Requests should be the highest priority authorized by Force Activity Designator (FAD). If the delivery is forecasted to be in excess of 21 days; or if materials are not received within 21 days of ordering contact your local GSA Customer Service Center DSN 695-4865 as appropriate to specific item of concern. If unable to requisition items within the allotted time frame contact one of the POCs listed in this TB.

# TB 11-5840-384-20

c. Bulk and Consumable Materials.

NOMENCLATURE	PART NO/NSN	U/I	QUANTITY REQ
Cloth, cheesecloth, lint-free	8305-00-267-3015	YD	
Phosphate-free detergent		EA	

- 8. Special Tools, Jigs and Fixtures Required. Not applicable.
- 9. Inspection Procedures. Only applicable to Tactical Airspace Integration System redeploying.
- 10. Cleaning Procedures.

### NOTE

Keep in mind all warnings and cautions when performing any routine cleaning

#### IMPROPER CLEANING HAZARD

This equipment can be damaged by improper cleaning.

Use only soft cloth slightly dampened with water or mild glass cleaner.

Do not scrape with hard plastic or metal tools.

Do not use alcohol, toluene, acetone, methyl ethyl ketone (MEK), volatile liquids, or harsh cleaning agents.

Do not use scouring powder or other gritty cleansers.

- a. Using a lint-free cloth, clean exterior surfaces of equipment and mechanical assemblies.
- b. With a clean lint-free cloth and soft-bristled brush, clean plugs, jacks, and front panel controls and indicators. Meter faces and front panels may be cleaned using a weak solution of water and mild soap. Avoid excessive amount of solution on cloth and do not let solution enter behind controls or panel mounting hardware of controls and indicators.
- c. Clean exterior and pins of connectors of interconnecting cables with a brush.
- d. Inspect/clean:
  - Generator and trailer (refer to TM 9-6115-661-13&P)
  - Power vault, racks, DTS (refer to TM M1139)
  - Filters: ADSI processor filter / UPS air filter / Ultra 80 workstation / ECU (includes fresh air filter) / voice recorder (two filters) - wash filter in warm water using mild detergent, rinse, shake off excess and allow to dry.
  - Inspect/clean as needed - ECU drain hose, radios, secure phones, UPS, AccessNet main switch, Access points, printer, GPS
  - Monitors - Wipe monitor screen with lint-free cloth dampened with glass cleaner or water.

11. Weight and Balance. Not applicable.

12. Recording and Reporting Requirements. Not applicable.

13. Points of Contact.

- a. Point of contact for this action is ATSCOM, ATTN:AFATS-S4-MR DSN 558-3494 or Commercial 334-255-3494
- b. Technical point of contact is ATSCOM, ATTN:AFATS-S4-MR DSN 558-3494 or Commercial 334-255-3494

**CHAPTER 5.**

1. Purpose. Provide a cleaning requirement to remove salt / salt laden sand and other corrosive contaminants from Tactical Terminal Control System AN/TSQ-198 returning from OCONUS Desert Operations. Environmental conditions within the Southwest Asia (SWA) theater of operations were conducive to the introduction of salt laden sand and other corrosive substances into the interior surfaces of the Tactical Terminal Control System. These substances, if allowed to remain will accelerate the corrosion process and lead to premature corrosion damage. Immediate removal of these Substances is imperative in order to minimize future corrosion damage. This Technical Bulletin (TB) is issued to provide special inspection and cleaning procedures for all deployed/redeployed Tactical Terminal Control System.
2. Priority Classification. NORMAL.
  - a. Equipment In Use. No later than 30 days after redeployment from Desert operations. Deployed Tactical Terminal Control System will complete cleaning procedures as necessary but as a minimum at next PMCS.
  - b. Equipment in Storage. No later than 30 clays after redeployment from Desert Operations. Equipment deployed will complete cleaning procedures as necessary but as a minimum quarterly.
3. End Items to be Inspected. All Tactical Terminal Control System after redeployment from Desert operations. Deployed Tactical Terminal Control System will complete requirements as necessary but at a minimum at next PMCS.
4. Assembly Components to be Inspected. Not applicable
5. Parts to be Inspected. Not applicable.
6. Application.
  - a. Category of Maintenance - Organizational/Direct Support (UNIT Level).
  - b. Time Required. As required to comply with this TB.
  - c. Estimated Cost Impact of Stock Fund Items to the Field. Not applicable.
  - d. TB / MWOs applied prior to or concurrently with this inspection. Not applicable.
  - e. Publications which require change as a result of this inspection. Not applicable.
7. Supply / Parts and Disposition.
  - a. Parts Required. Not applicable.
  - b. Requisitioning Instructions. Requisition materials through normal supply channels using normal supply procedures. Requests should be the highest priority authorized by Force Activity Designator (FAD). If the delivery is forecasted to be in excess of 21 days; or if materials are not received within 21 days of ordering contact your local GSA Customer Service Center DSN 695-4865 as appropriate to specific item of concern. If unable to requisition items within the allotted time frame contact one of the POCs listed in this TB.

# TB 11-5840-384-20

c. Bulk and Consumable Materials.

NOMENCLATURE	PART NO/NSN	U/I	QUANTITY REQ
SD-2			

- 8. Special Tools, Jigs and Fixtures Required. Not applicable.
- 9. Inspection Procedures. Only applicable to Tactical Terminal Control System redeploying.
- 10. Cleaning Procedures.

### NOTE

Keep in mind all warnings and cautions when performing any routine cleaning

Use dry cleaning solvent SD-2 on all metal surfaces. Use soap and water when you clean rubber or plastic material. When cleaning grease, use an approved cleaning solvent and apply a thin coat of light oil to the cleaned surfaces.

- a. Using a lint-free cloth, clean exterior surfaces of equipment and mechanical assemblies.
- b. With a clean lint-free cloth and soft-bristled brush, clean plugs, jacks, and front panel controls and indicators. Meter faces and front panels may be cleaned using a weak solution of water and mild soap. Avoid excessive amount of solution on cloth and do not let solution enter behind controls or panel mounting hardware of controls and indicators.
- c. Clean exterior and pins of connectors of interconnecting cables with a brush.
- d. Equipment housings; racks, generator set, HMMWV (IAW TM 9-2320-280-10), trailer (TM 9-2330-202-14&P)

**Tactical Terminal Control System AN/TSQ-198**

**Caution**

Be very careful of the ends of the fiber optic cables not to damage the connecting ends.

1. Remove cables for each LRU careful to tag and cap them, wipe each down with a damp cloth.
2. Loosen thumb screw of each LRU and remove to safe area away from rack.
3. Wipe down each LRU with damp Cloth, removing any dirt, sand or dust.
4. Brush, wipe and blow out empty rack of all debris.
5. Reinstall LRUs and reconnect cables.

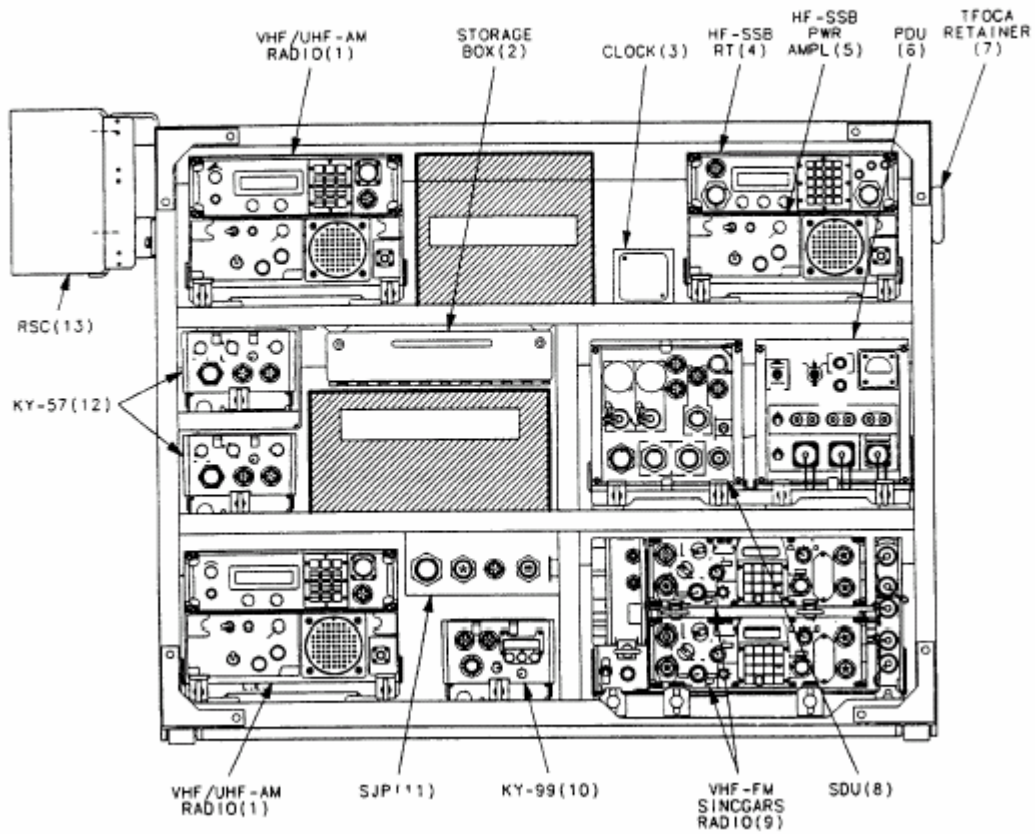

# TB 11-5840-384-20

## CHAPTER 6.

1. Purpose. Provide a cleaning requirement to remove salt / salt laden sand and other corrosive contaminants from BEACON SETS, RADIO AN/TRN-30(V) returning from OCONUS Desert Operations. Environmental conditions within the Southwest Asia (SWA) theater of operations were conducive to the introduction of salt laden sand and other corrosive substances into the interior surfaces of the BEACON SETS, RADIO AN/TRN-30(V). These substances, if allowed to remain will accelerate the corrosion process and lead to premature corrosion damage. Immediate removal of these Substances is imperative in order to minimize future corrosion damage. This Technical Bulletin (TB) is issued to provide special inspection and cleaning procedures for all deployed/redeployed BEACON SETS, RADIO AN/TRN-30(V).
2. Priority Classification. NORMAL.
  - a. Equipment In Use. No later than 30 days after redeployment from Desert operations. Deployed Tactical Terminal Control System will complete cleaning procedures as necessary but as a minimum at next PMCS.
  - b. Equipment in Storage. No later than 30 clays after redeployment from Desert Operations. Equipment deployed will complete cleaning procedures as necessary but as a minimum quarterly.
3. End Items to be Inspected. All Tactical Terminal Control System after redeployment from Desert operations. Deployed Tactical Terminal Control System will complete requirements as necessary but at a minimum at next PMCS.
4. Assembly Components to be Inspected. Not applicable
5. Parts to be Inspected. Not applicable.
6. Application.
  - a. Category of Maintenance - Organizational/Direct Support (UNIT Level).
  - b. Time Required. As required to comply with this TB.
  - c. Estimated Cost Impact of Stock Fund Items to the Field. Not applicable.
  - d. TB / MWOs applied prior to or concurrently with this inspection. Not applicable.
  - e. Publications which require change as a result of this inspection. Not applicable.
7. Supply / Parts and Disposition.
  - a. Parts Required. Not applicable.
  - b. Requisitioning Instructions. Requisition materials through normal supply channels using normal supply procedures. Requests should be the highest priority authorized by Force Activity Designator (FAD). If the delivery is forecasted to be in excess of 21 days; or if materials are not received within 21 days of ordering contact your local GSA Customer Service Center DSN 695-4865 as appropriate to specific item of concern. If unable to requisition items within the allotted time frame contact one of the POCs listed in this TB.
  - c. Bulk and Consumable Materials.

NOMENCLATURE	PART NO/NSN	U/I	QUANTITY REQ

8. Special Tools, Jigs and Fixtures Required. Not applicable.
9. Inspection Procedures. Only applicable to BEACON SETS, RADIO AN/TRN-30(V) redeploying.
10. Cleaning Procedures.

**NOTE**

Keep in mind all warnings and cautions when performing any routine cleaning

**IMPROPER CLEANING HAZARD**

This equipment can be damaged by improper cleaning.

Use only soft cloth slightly dampened with water or mild glass cleaner.

Do not scrape with hard plastic or metal tools.

Do not use alcohol, toluene, acetone, methyl ethyl ketone (MEK), volatile liquids, or harsh cleaning agents.

Do not use scouring powder or other gritty cleansers.

- a. Using a lint-free cloth, clean exterior surfaces of equipment and mechanical assemblies.
- b. With a clean lint-free cloth and soft-bristled brush, clean plugs, jacks, and front panel controls and indicators. Meter faces and front panels may be cleaned using a weak solution of water and mild soap. Avoid excessive amount of solution on cloth and do not let solution enter behind controls or panel mounting hardware of controls and indicators.
- c. Clean exterior and pins of connectors of interconnecting cables with a brush.
- d. Inspect/clean:

# TB 11-5840-384-20

Beacon Set, Radio AN/TRN-30(V)

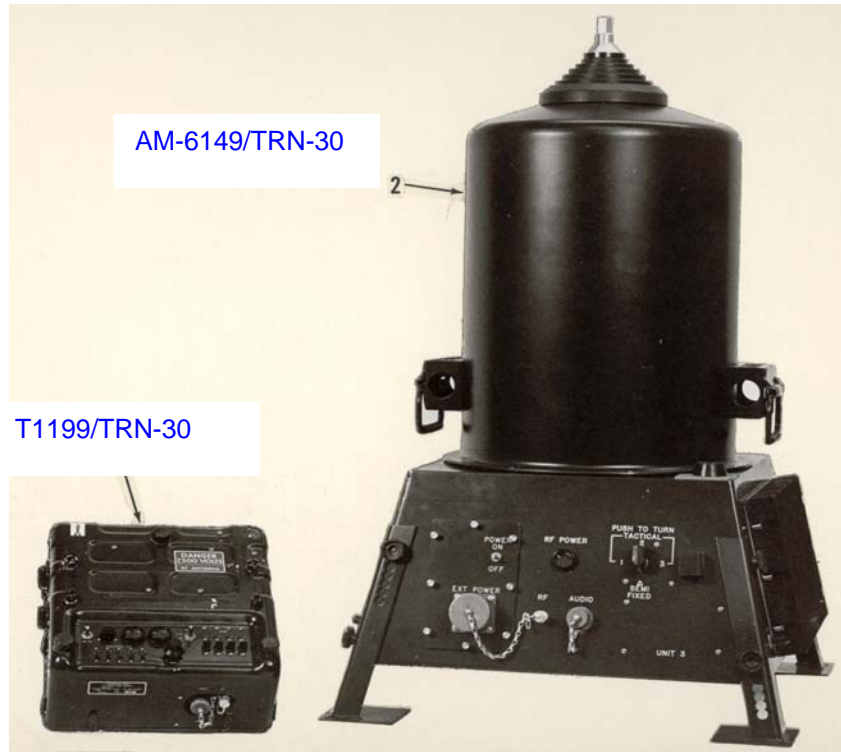

### CAUTION

Do not use compressed air or high pressure water

- a. Using a lint-free cloth, clean exterior surfaces of equipment and mechanical assemblies.
- b. On the T1199/TRN-30: Remove bottom cover (12 snap fasteners) and shake out dust/dirt.
- c. With a clean lint-free cloth and soft-bristled brush, .
- d. Clean exterior and pins of connectors of interconnecting cables with a brush.

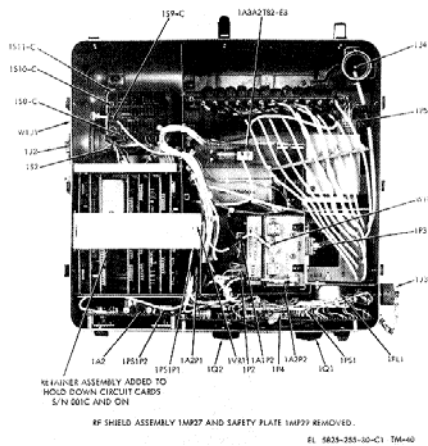



NOTE

Due to delicate components DO NOT try to disassemble in the field.



AM-6149/TRN-30: The amplifier coupler should not be opened. If it was operational until packing/redeployment the system has minimal inside dirt. It should not be opened until it is turned over to support maintenance. Organizational maintenance should only brush, wipe, and damp cloth clean only. **Do not use compressed air or high pressure water!**

**CHAPTER 7.**

1. Purpose. Provide a cleaning requirement to remove salt / salt laden sand and other corrosive contaminants from ATNAVICS returning from OCONUS Desert Operations. Environmental conditions within the Southwest Asia (SWA) theater of operations were conducive to the introduction of salt laden sand and other corrosive substances into the interior surfaces of the ATNAVICS. These substances, if allowed to remain, will accelerate the corrosion process and lead to premature corrosion damage. Immediate removal of these Substances is imperative in order to minimize future corrosion damage. This Technical Bulletin (TB) is issued to provide special inspection and cleaning procedures for all deployed/redeployed ATNAVICS.
2. Priority Classification. NORMAL.
  - a. Equipment In Use. No later than 30 days after redeployment from Desert operations. Deployed ATNAVICS will complete cleaning procedures as necessary but as a minimum at next PMCS.
  - b. Equipment in Storage. No later than 30 clays after redeployment from Desert Operations. Equipment deployed will complete cleaning procedures as necessary but as a minimum quarterly.
3. End Items to be Inspected. All ATNAVICS after redeployment from Desert operations. Deployed ATNAVICS will complete requirements as necessary but at a minimum at next PMCS.
4. Assembly Components to be Inspected. Not applicable
5. Parts to be inspected. Not applicable.
6. Application.
  - a. Category of Maintenance - Organizational/Direct Support (UNIT Level).
  - b. Time Required. As required to comply with this TB.
  - c. Estimated Cost Impact of Stock Fund Items to the Field. Not applicable.
  - d. TB / MWOs applied prior to or concurrently with this inspection. Not applicable.
  - e. Publications which require change as a result of this inspection. Not applicable.
7. Supply / Parts and Disposition.
  - a. Parts Required. Not applicable.
  - b. Requisitioning Instructions. Requisition materials through normal supply channels using normal supply procedures. Requests should be the highest priority authorized by Force Activity Designator (FAD). If the delivery is forecasted to be in excess of 21 days; or if materials are not received within 21 days of ordering contact your local GSA Customer Service Center as appropriate to specific item of concern. If unable to requisition items within the allotted time frame contact one of the POCs listed in this TB. Bulk and Consumable Materials.

c. Bulk and Consumable Materials.

<b>NOMENCLATURE</b>	<b>PART NO/NSN</b>	<b>U/I</b>	<b>QUANTITY REQ</b>
Cloth, cheesecloth, lint-free	8305-00-267-3015	YD	
Phosphate-free detergent		EA	

8. Special Tools, Jigs and Fixtures Required. Not applicable.
9. Inspection Procedures. Only applicable to ATNAVICS redeploying.
10. Cleaning Procedures.

**NOTE**

Keep in mind all warnings and cautions when performing any routine cleaning

**IMPROPER CLEANING HAZARD**

This equipment can be damaged by improper cleaning.

- Use only soft cloth slightly dampened with water or mild glass cleaner.
  - Do not scrape with hard plastic or metal tools.
  - Do not use alcohol, toluene, acetone, methyl ethyl ketone (MEK), volatile liquids, or harsh cleaning agents.
  - Do not use scouring powder or other gritty cleansers.
- a. Using a lint-free cloth, clean exterior surfaces of equipment and mechanical assemblies.
  - b. With a clean lint-free cloth and soft-bristled brush, clean plugs, jacks, and front panel controls and indicators. Meter faces and front panels may be cleaned using a weak solution of water and mild soap. Avoid excessive amount of solution on cloth and do not let solution enter behind controls or panel mounting hardware of controls and indicators.
  - c. Vacuum or sweep Operations Shelter floor.
  - d. Clean exterior and pins of connectors of interconnecting cables with a brush.
  - e. Inspect/clean:
    - Generator and trailer (refer to TM 9-6115-642-10)
    - Power vault, racks, ASR, SSR/IFF and UPS
    - ECU filters / GPFU filters (if installed) / workstation  
wash filter in warm water using mild detergent, rinse, shake off excess and allow to dry.
    - Inspect/clean as needed - ECU drain hose, radios, secure phones, access points, printer, GPS
    - Monitors - Wipe monitor screen with lint-free cloth dampened with glass cleaner or water.
11. Weight and Balance. Not applicable.
  12. Recording and Reporting Requirements. Not applicable.

**CHAPTER 8**

1. Points of Contact.
  - a. Point of contact for this action is ATSCOM, ATTN:AFATS-S4-MR DSN 558-3494 or Commercial 334-255-3494.
  - b. Technical point of contact is ATSCOM, ATTN:AFATS-S4-MR DSN 558-3494 or Commercial 334-255-3494.
2. You can help improve this publication. If you find any mistakes or if you know of a way to improve the procedures, please let us know. Mail your letter or DA Form 2028 (Recommended Changes to Publications and Blank Forms) directly to : Commander, U.S. Army Aviation Systems Command, ATTN:  
A reply will be furnished to you.

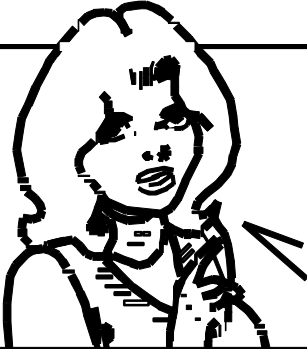

**SOMETHING WRONG WITH THIS PUBLICATION**

THEN ... JOT DOWN THE INFO ABOUT IT ON THIS FORM. CAREFULLY TEAR IT OUT. FOLD IT AND DROP IT IN THE MAIL.

FROM: (PRINT YOUR UNIT'S COMPLETE ADDRESS)  
 Commander  
 Stateside Army Depot  
 ATTN: AMSTA-US  
 Stateside, N.J. 07703-5007

---

DATE SENT  
 10 July 1975

PUBLICATION NUMBER TM 11-5840-340-20	PUBLICATION DATE 23 Jan 74	PUBLICATION TITLE Radar Set AN/PRC-76
---	-------------------------------	--

BE EXACT PIN-POINT WHERE IT IS				IN THIS SPACE TELL WHAT IS WRONG AND WHAT SHOULD BE DONE ABOUT IT:
PAGE NO	PARA GRAPH	FIGURE NO	TABLE NO	
2-25	2-28			<p>Recommend that the installation antenna alignment procedure be changed throughout to specify a 20 IFF antenna lag rather than 10.</p> <p>REASON: Experience has shown that with only a 10 lag, the antenna servo system is too sensitive to wind gusting in excess of 25 knots, and has a tendency to rapidly accelerate and decelerate as it hunts, causing strain to the drive train. Hunting is minimized by adjusting the lag to 20 without degradation of operation.</p>
3-10	3-3		3-1	<p>Item 5, Functional column. Change 2 dB" to 3 dB".</p> <p>REASON: The adjustment procedure for the TRANS POWER FAULT indicator calls for a 3 dB (500 watts) adjustment to light the TRANS POWER FAULT indicator.</p>
5-6	5-8			<p>Add new step f.1 to read, "Replace cover plate removed in step e.1, above."</p> <p>REASON: To replace the cover plate.</p>
		FO-3		<p>Zone C 3. On J1-2, change +24 VDC" to +5 VDC".</p> <p>REASON: This is the output line of the 5 VDC power supply. +24 VDC is the input voltage.</p>

TEAR ALONG DOTTED LINE

PRINTED NAME, GRADE OR TITLE AND TELEPHONE NUMBER SSG I. M. DeSpirito 999-1776	SIGN HERE 
---	---------------

FILL IN YOUR  
UNIT'S ADDRESS

FOLD BACK

DEPARTMENT OF THE ARMY

\_\_\_\_\_  
\_\_\_\_\_

OFFICIAL BUSINESS

PLEASE  
AFFIX  
STAMP  
POSTAGE  
REQUIRED

**SAMPLE**

Commander  
U.S. Army Communications-Electronics Command  
and Fort Monmouth  
ATTN: AMSEL-LC-LEO-E-ED  
Fort Monmouth, New Jersey 07703-5006

TEAR ALONG DOTTED LINE

# SOMETHING WRONG WITH THIS PUBLICATION



*THEN ... JOT DOWN THE INFO ABOUT IT ON THIS FORM. CAREFULLY TEAR IT OUT. FOLD IT AND DROP IT IN THE MAIL.*

FROM: (PRINT YOUR UNIT'S COMPLETE ADDRESS)

DATE SENT

PUBLICATION NUMBER

PUBLICATION DATE

PUBLICATION TITLE

BE EXACT PIN-POINT WHERE IT IS

IN THIS SPACE TELL WHAT IS WRONG AND WHAT SHOULD BE DONE ABOUT IT:

PAGE NO

PARA GRAPH

FIGURE NO

TABLE NO

TEAR ALONG DOTTED LINE

PRINTED NAME, GRADE OR TITLE AND TELEPHONE NUMBER

SIGN HERE

FILL IN YOUR  
UNIT'S ADDRESS

FOLD BACK

DEPARTMENT OF THE ARMY



OFFICIAL BUSINESS

PLEASE  
AFFIX  
STAMP  
POSTAGE  
REQUIRED

TEAR ALONG DOTTED LINE

**Commander**  
**U.S. Army Communications-Electronics Command**  
**and Fort Monmouth**  
**ATTN: AMSEL-LC-LEO-E-ED**  
**Fort Monmouth, New Jersey 07703-5006**



# SOMETHING WRONG WITH THIS PUBLICATION



*THEN ... JOT DOWN THE INFO ABOUT IT ON THIS FORM. CAREFULLY TEAR IT OUT. FOLD IT AND DROP IT IN THE MAIL.*

FROM: (PRINT YOUR UNIT'S COMPLETE ADDRESS)

DATE SENT

PUBLICATION NUMBER

PUBLICATION DATE

PUBLICATION TITLE

BE EXACT PIN-POINT WHERE IT IS

IN THIS SPACE TELL WHAT IS WRONG AND WHAT SHOULD BE DONE ABOUT IT:

PAGE NO

PARA GRAPH

FIGURE NO

TABLE NO

TEAR ALONG DOTTED LINE

PRINTED NAME, GRADE OR TITLE AND TELEPHONE NUMBER

SIGN HERE

FILL IN YOUR  
UNIT'S ADDRESS

FOLD BACK

DEPARTMENT OF THE ARMY

\_\_\_\_\_  
\_\_\_\_\_

OFFICIAL BUSINESS

PLEASE  
AFFIX  
STAMP  
POSTAGE  
REQUIRED

TEAR ALONG DOTTED LINE

**Commander**  
**U.S. Army Communications-Electronics Command**  
**and Fort Monmouth**  
**ATTN: AMSEL-LC-LEO-E-ED**  
**Fort Monmouth, New Jersey 07703-5006**

# SOMETHING WRONG WITH THIS PUBLICATION



THEN ... JOT DOWN THE INFO ABOUT IT ON THIS FORM. CAREFULLY TEAR IT OUT. FOLD IT AND DROP IT IN THE MAIL.

FROM: (PRINT YOUR UNIT'S COMPLETE ADDRESS)

DATE SENT

PUBLICATION NUMBER

PUBLICATION DATE

PUBLICATION TITLE

BE EXACT PIN-POINT WHERE IT IS

IN THIS SPACE TELL WHAT IS WRONG AND WHAT SHOULD BE DONE ABOUT IT:

PAGE NO

PARA GRAPH

FIGURE NO

TABLE NO

TEAR ALONG DOTTED LINE

PRINTED NAME, GRADE OR TITLE AND TELEPHONE NUMBER

SIGN HERE

FILL IN YOUR  
UNIT'S ADDRESS

FOLD BACK

DEPARTMENT OF THE ARMY



OFFICIAL BUSINESS

PLEASE  
AFFIX  
STAMP  
POSTAGE  
REQUIRED

TEAR ALONG DOTTED LINE

**Commander**  
**U.S. Army Communications-Electronics Command**  
**and Fort Monmouth**  
**ATTN: AMSEL-LC-LEO-E-ED**  
**Fort Monmouth, New Jersey 07703-5006**

By Order of the Secretary of the Army:

Official:



JOYCE E. MORROW

*Administrative Assistant to the  
Secretary of the Army 0616401*

PETER J. SCHOOMAKER  
*General, United States Army  
Chief of Staff*

DISTRIBUTION:

To be distributed in accordance with the initial distribution number (IDN) 344800 requirements for TB 11-5840-384-20.





